

TECHNICAL BULLETIN- KUBOTA 95 PISTON SET

USHA is pleased to introduce **KUBOTA 95** piston set in our tractor/ tiller product range.

PISTON:

Unique features of **KUBOTA 95** piston are as follows:

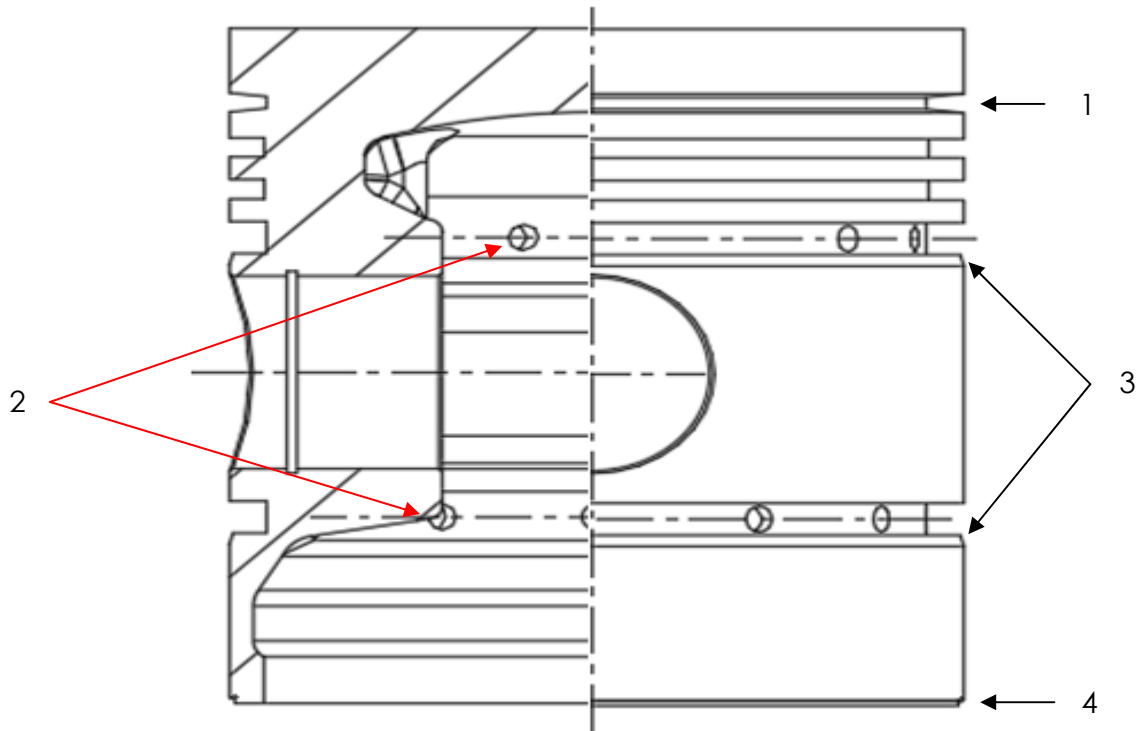

S.No.	SPECIAL FEATURES	BENEFITS TO CUSTOMERS
1)	HALF KEYSTONE TOP RING GROOVE	<ul style="list-style-type: none"> Helps in preventing carbon deposition & ring sticking in the groove.
2)	OIL HOLES IN 4th & 5th RING GROOVE	<ul style="list-style-type: none"> Faster drainage of excess oil. Lesser oil consumption.
3)	CHAMFER AT BOTTOM FLANK OF BOTH 4th & 5th OIL RING GROOVE	<ul style="list-style-type: none"> Low oil consumption. Reduction in skirt wear.
4)	SCRAPER NOTCH: An all round notch is provided at the bottom portion of the piston.	<ul style="list-style-type: none"> Helps in scraping excess oil from cylinder liner surface.

TECHNICAL DATA- KUBOTA 95 PISTON

USHA CODE→ S46		
Nominal Bore Diameter	mm	95.00
Piston Diameter	STD Size mm	94.885
Recommended Piston-Liner Clearance	mm	0.115
Compression Height	mm	53.50
Total Height	mm	105.00
Piston Pin- Pin Bore Clearance	mm	+0.005 to +0.017 (Clearance Fit)

PISTON RINGS:

The piston is designed to match with existing USHA Kubota 95 "TC" ring set for better performance.