



SHRIRAM PISTONS & RINGS

MD: TS: 12/NOV'22

INTRODUCTION CIRCULAR – **HONDA ACTIVA 125cc BS-VI – PISTON ASSEMBLY**

USHA is pleased to launch **Honda Activa 125cc BS-VI** piston assembly in its Bi-wheeler product range in aftermarket.



This piston assembly has following special features:-

PISTON:-

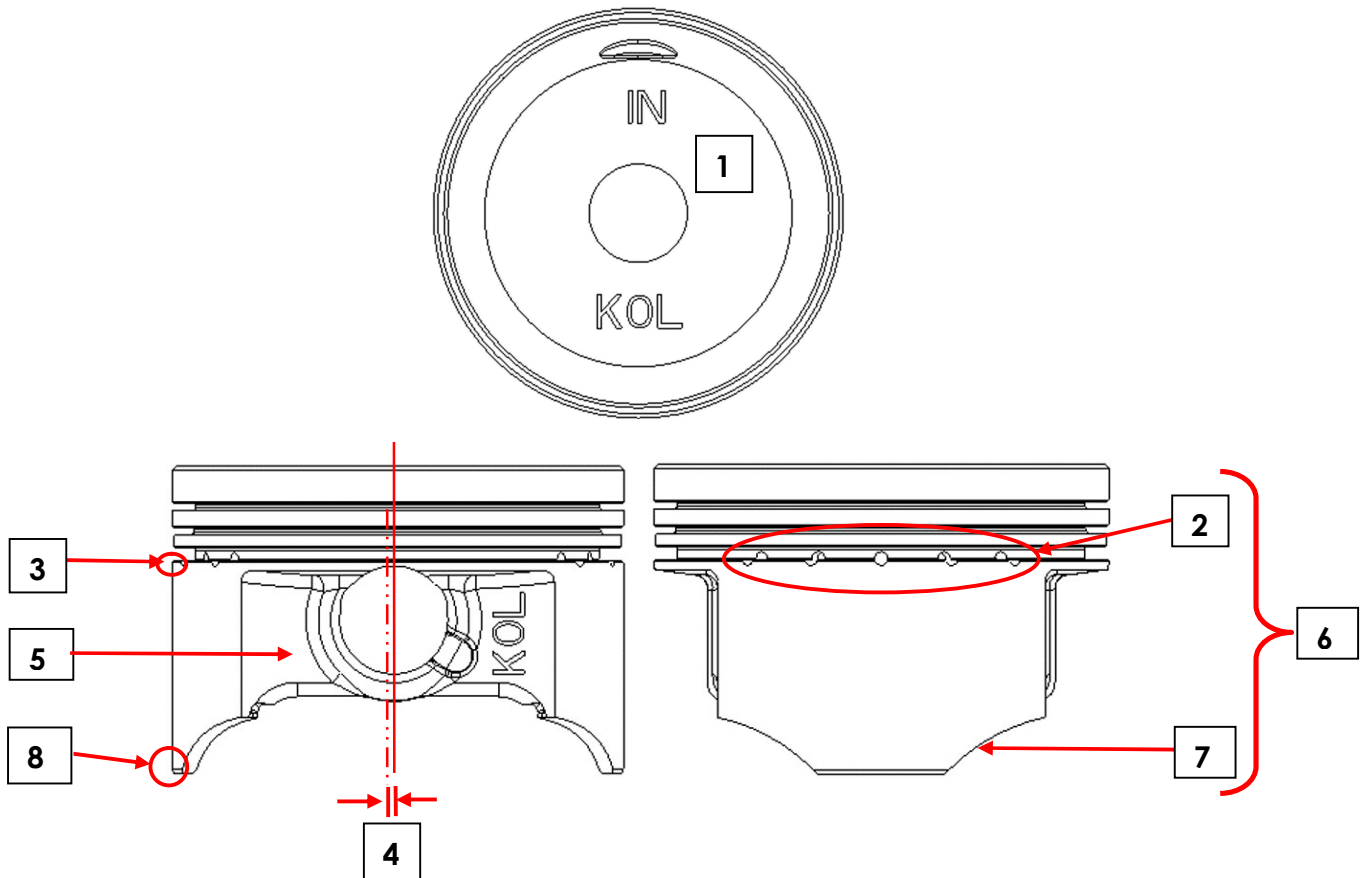



Unique features of USHA 'Honda Activa 125cc BS-VI' piston are as follows:-

SL. NO.	SPECIAL FEATURE	BENEFITS TO CUSTOMER
1)	AS CAST CROWN: The crown of Honda Activa 125cc BS-VI piston is not machined and is as cast. As cast crown has better grain structure which improves piston strength & heat resistance etc.	<ul style="list-style-type: none"> Improves piston life
2)	OIL HOLES IN RING GROOVE AREA: This piston has been provided with 05 nos. of oil holes on each side of piston, half in the oil ring groove & half in the skirt.	<ul style="list-style-type: none"> Faster drainage of excess oil Reduced oil consumption
3)	CHAMFER AT BOTTOM OF OIL RING GROOVE: Honda Activa 125cc BS-VI piston has been provided with an all-round chamfer just below the oil ring groove area.	<ul style="list-style-type: none"> Provides all time lubrication to piston skirt No piston seizure in extreme limits of normal working conditions
4)	PISTON - PIN BORE OFFSET: This piston is provided with piston pin bore offset to avoid piston slap. Piston pin bore offset means that the centre line of piston is slightly offset from the centre line of pin bore. Due to this offset, piston tilts at TDC & BDC smoothly & prevents slapping with liner.	<ul style="list-style-type: none"> Reduced engine noise
5)	AS CAST RELIEF IN PIN BORE AREA: Honda Activa 125cc BS-VI piston is provided with as cast relief in pin bore area which helps in faster drainage of oil towards sump, avoiding chances of seizure on minor axis.	<ul style="list-style-type: none"> Low oil consumption Longer life
6)	TIN PLATING: Entire surface of Honda Activa 125cc BS-VI piston is tin plated. Tin plating is a slippery coating which helps in avoiding metal to metal contact during initial run-in period.	<ul style="list-style-type: none"> Reduces friction Avoids piston scuffing
7)	SLIPPER DESIGN: This piston is provided with Slipper design which helps in reducing piston weight.	<ul style="list-style-type: none"> Improved fuel efficiency Low noise during engine working
8)	SCRAPPING CHAMFER: A smooth chamfer is provided at the bottom end of the piston skirt.	<ul style="list-style-type: none"> Helps in regulating oil supply, reduces skirt wear & hence longer life

TECHNICAL DATA – 'HONDA ACTIVA 125cc BS-VI' PISTON		
USHA CODE → NCS78		
Nominal Bore Diameter	mm	50.00
Piston Diameter	STD Size mm	49.99
Recommended Piston-Liner Clearance	mm	00.01
Compression Height	mm	17.20
Total Height	mm	34.20
Gudgeon Pin OD X Length	mm	12.00 X 32.00

PISTON RINGS:-

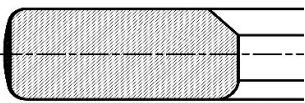
USHA 'Honda Activa 125cc BS-VI' piston is supplied with a unique **All steel '3S IPVENT'** ring set for no smoke, low oil & fuel consumption. The technical details of '3S IPVENT' ring set are as under:-

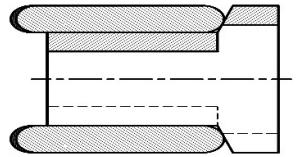
TECHNICAL DATA – 'HONDA ACTIVA 125cc BS-VI' – '3S IPVENT' RINGS						
Ring	Ring Configuration	Axial Thickness (mm)	Closed Gap		Surface Treatment	Cross Section
			(mm)	(Thou)		
Top	Inside Bevel Steel (HPIBIP)	0.80	0.07-0.12	03-05	Ion Plating/ Parkerising	
Second	Taper Steel (HPCRT)	0.80	0.12-0.22	05-09	Chrome Plating/ Parkerising	
Oil	RIKVENT	1.50	0.10-0.35 (Rails)	04-14	Ion Plating & Parkerising on rails	

Above features make USHA 'Honda Activa 125cc BS-VI' piston assembly unique, produced to give better performance & longer life.



Technical Product News is an exclusive update of product & information from Shriram Pistons & Rings Ltd., 3rd Floor, Himalaya House, 23, Kasturba Gandhi Marg, New Delhi-110001
 Tel: 011-46451100, 23315941, Email: tss@shrirampistons.com, Website: www.shrirampistons.com