



SHRIRAM PISTONS & RINGS

MD: TS:18/JAN'23 INTRODUCTION CIRCULAR – HONDA CD DREAM DELUXE/ LIVO 110cc BS-VI – PISTON ASSEMBLY

USHA is pleased to launch **Honda CD Dream Deluxe/ Livo 110cc BS-VI** piston assembly in its Bi-wheeler product range.



This piston assembly has following special features:-

PISTON:-

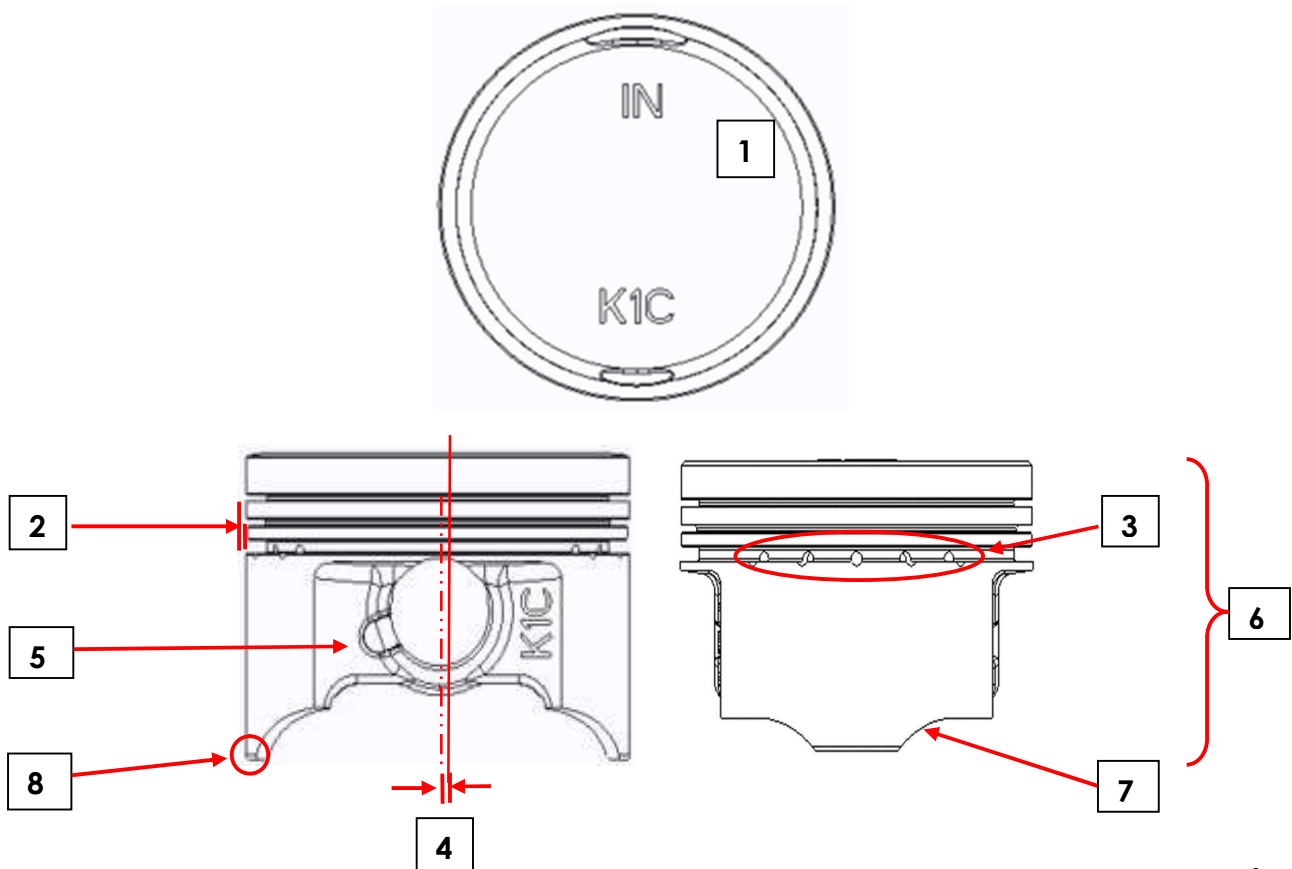



Unique features of USHA 'Honda CD Dream Deluxe/Livo 110cc BS-VI' piston are as follows:-

SL. NO.	SPECIAL FEATURE	BENEFITS TO CUSTOMER
1)	AS CAST CROWN: The crown of Honda CD Dream Deluxe/ Livo BS-VI piston is not machined and is as cast. As cast crown has better grain structure which improves piston strength & heat resistance etc.	<ul style="list-style-type: none"> Improves piston life
2)	CUT BACK IN SECOND RING LAND: This piston is provided with a cut back in second ring land for better seating, stability & functioning of intermediate ring.	<ul style="list-style-type: none"> Helps in controlling blow-by & reduced oil consumption
3)	OIL HOLES IN RING GROOVE AREA: Honda CD Dream Deluxe/ Livo BS-VI piston has been provided with 05 nos. of oil holes on each side of piston, half in the oil ring groove & half in the skirt.	<ul style="list-style-type: none"> Faster drainage of excess oil Reduced oil consumption
4)	PISTON - PIN BORE OFFSET: This piston is provided with piston pin bore offset to avoid piston slap. Piston pin bore offset means that the centre line of piston is slightly offset from the centre line of pin bore. Due to this offset, piston tilts at TDC & BDC smoothly & prevents slapping with liner.	<ul style="list-style-type: none"> Reduced engine noise
5)	AS CAST RELIEF IN PIN BORE AREA: Honda CD Dream Deluxe/ Livo BS-VI piston is provided with as cast relief in pin bore area which helps in faster drainage of oil towards sump, avoiding chances of seizure on minor axis.	<ul style="list-style-type: none"> Low oil consumption Longer life
6)	TIN PLATING: Entire surface of this piston is tin plated. Tin plating is a slippery coating which helps in avoiding metal to metal contact during initial run-in period.	<ul style="list-style-type: none"> Reduces friction Avoids piston scuffing
7)	SLIPPER DESIGN: Honda CD Dream Deluxe/ Livo BS-VI is provided with Slipper design which helps in reducing piston weight.	<ul style="list-style-type: none"> Improves fuel efficiency Low noise during engine working
8)	SCRAPPING CHAMFER: A smooth chamfer is provided at the bottom end of the piston skirt.	<ul style="list-style-type: none"> Helps in regulating oil supply, reduces skirt wear & hence longer life

TECHNICAL DATA – 'HONDA CD DREAM DELUXE/ LIVO 110cc BS-VI' PISTON		
USHA CODE → NCS79		
Nominal Bore Diameter	mm	47.000
Piston Diameter	STD Size mm	46.990
Recommended Piston-Liner Clearance	mm	00.010
Compression Height	mm	17.400
Total Height	mm	33.800
Gudgeon Pin OD X Length	mm	12.00 X 32.00

PISTON RINGS:-

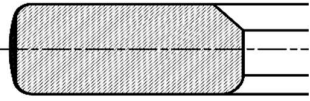
USHA 'Honda CD Dream Deluxe/ Livo 110cc BS-VI' piston is supplied with a unique **All steel, Ion Plated rails & Top ring, '3S IPVENT'** low closed gap ring set for no smoke, low oil & fuel consumption. The technical details of '3S IPVENT' ring set are as under:

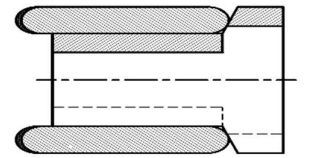
TECHNICAL DATA – 'HONDA CD DREAM DELUXE/ LIVO 110cc' – '3S IPVENT' RINGS						
Ring	Ring Configuration	Axial Thickness (mm)	Closed Gap		Surface Treatment	Cross Section
			(mm)	(Thou)		
Top	Inside Bevel Steel (HPIBIP)	0.80	0.07-0.12	03-05	Ion Plating/ Parkerising	
Second	Taper Steel (HPCRT)	0.80	0.12-0.22	05-09	Chrome Plating/ Parkerising	
Oil	RIKVENT	1.50	0.10-0.35 (Rails)	04-14	Rails Ion Plating/ Parkerising	

Above features make USHA 'Honda CD Dream Deluxe/ Livo 110cc BS-VI' piston assembly unique, produced to give better performance & longer life.

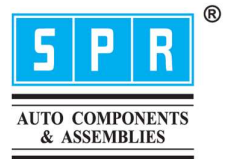

Technical Product News is an exclusive update of product & information from Shriram Pistons & Rings Ltd., 3rd Floor, Himalaya House, 23, Kasturba Gandhi Marg, New Delhi-110001
 Tel: 011-46451100, 23315941, Email: tss@shrirampistons.com, Website: www.shrirampistons.com