



SHRIRAM PISTONS & RINGS

MD: TS: 03/MAY'23

INTRODUCTION CIRCULAR – **MARUTI ERTIGA/ VITARA BREZZA/ CIAZ 1.5L (P) (2018 onwards) – PISTON SET**

USHA is pleased to launch **Maruti Ertiga/ Vitara Brezza/ Ciaz 1.5L Petrol (2018 onwards)** piston set in its Car product range.



This piston set has following special features:

PISTON:

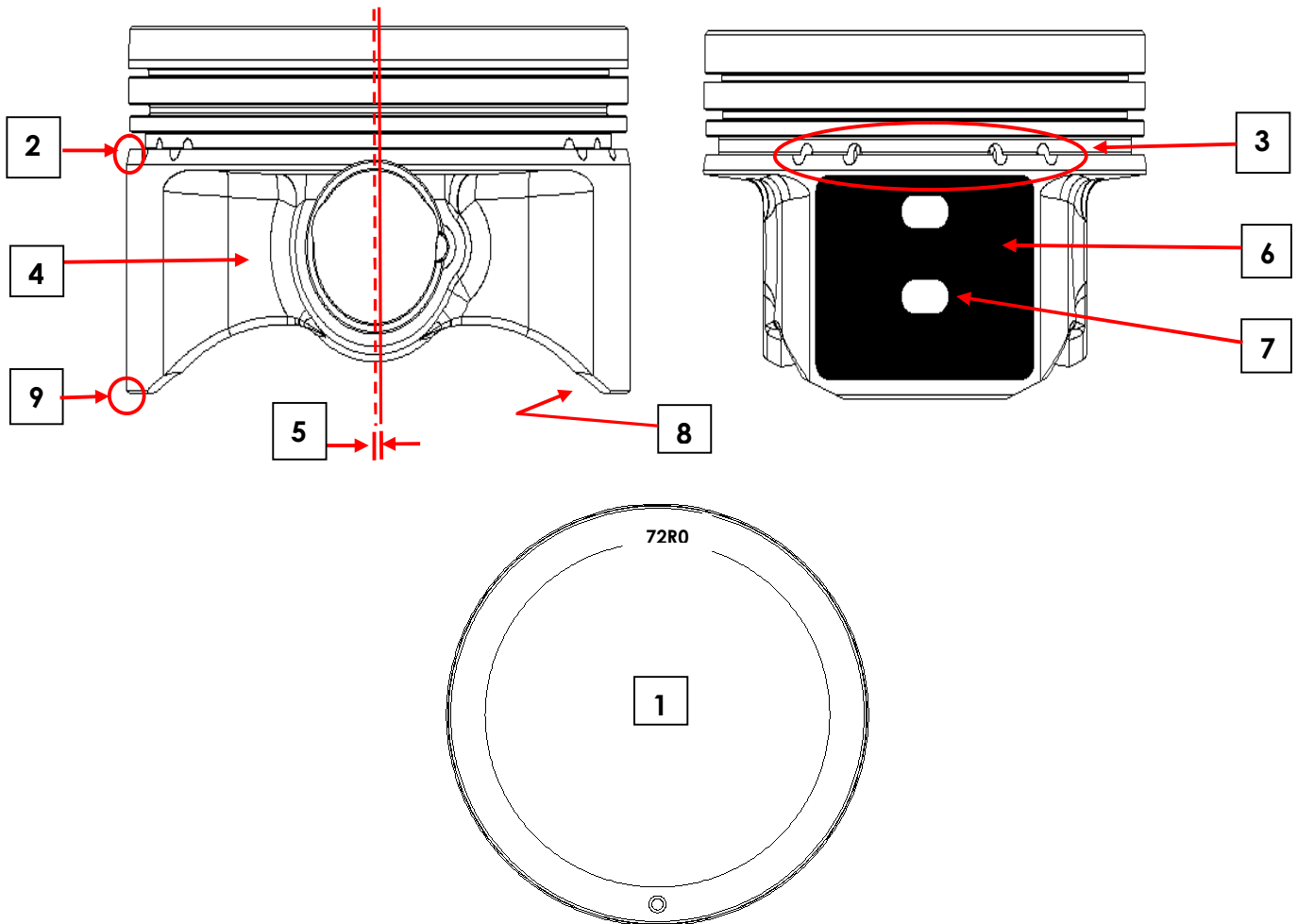

Unique features of this piston are as follows: -

SL. NO.	SPECIAL FEATURE	BENEFITS TO CUSTOMER
1)	SHALLOW CAVITY: USHA Maruti Ertiga/ Vitara Brezza/ Ciaz 1.5L Petrol (2018 onwards) piston crown is provided with a shallow machined cavity for an effective combustion.	<ul style="list-style-type: none"> • Low emissions • Better fuel efficiency
2)	CHAMFER AT BOTTOM OF OIL RING GROOVE: This piston has an all-round chamfer just below the oil ring groove area.	<ul style="list-style-type: none"> • Provides all time lubrication to piston skirt • No piston seizure in extreme limits of normal working conditions
3)	HOLES IN OIL RING GROOVE AREA: 04 nos. of holes are provided on either side of piston, half in groove & half in window.	<ul style="list-style-type: none"> • Faster drainage of excess oil • Reduced oil consumption
4)	AS CAST RELIEF IN PIN BORE AREA: As cast relief in pin bore area not only helps in faster drainage of oil towards sump but also in avoiding chances of seizure on minor axis.	<ul style="list-style-type: none"> • Low oil consumption • Longer life
5)	PISTON - PIN BORE OFFSET: Piston pin bore offset is provided to avoid piston slap. Piston pin bore offset means that the centre line of piston is slightly offset from the centre line of pin bore. Due to this offset, piston tilts at TDC & BDC smoothly, that prevents slapping with liner.	<ul style="list-style-type: none"> • Reduced engine noise
6)	'D-10 COATING' ON PISTON SKIRT:	<ul style="list-style-type: none"> • Helps in initial lubrication & seizure free operation • Better wear resistance • Reduces engine noise
7)	MEASURING POINTS ON PISTON SKIRT:	<ul style="list-style-type: none"> • Provided for easy diameter verification
8)	SLIPPER DESIGN: Slipper design helps in reducing piston weight.	<ul style="list-style-type: none"> • Improves fuel efficiency • Low noise during engine working
9)	SCRAPPING CHAMFER: A smooth chamfer is provided at the bottom end of the piston skirt.	<ul style="list-style-type: none"> • Helps in regulating oil supply, reduces skirt wear & hence longer life

TECHNICAL DATA – 'MARUTI ERTIGA/ VITARA BREZZA/ CIAZ 1.5L PETROL' (2018 onwards) PISTON		
		USHA CODE → C31
Nominal Bore Diameter	mm	74.0
Piston Diameter	STD Size mm	73.990
Recommended Piston-Liner Clearance	mm	0.010
Compression Height	mm	26.0
Total Height	mm	43.25
Piston Pin length X diameter	mm	48.0 X 18.0
Piston Pin- Pin Bore Clearance	mm	+0.006 to +0.019 (Clearance fit)

You will find '**72R0**' mark punched on crown of this piston.

Above features make USHA '**Ertiga/ Vitara Brezza/ Ciaz 1.5L Petrol (2018 onwards)**' piston set unique, produced to give better performance & longer life especially when fitted with matching USHA rings.

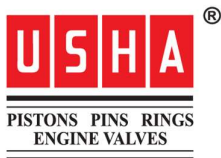

Technical Product News is an exclusive update of product & information from
 Shriram Pistons & Rings Ltd., 3rd Floor, Himalaya House, 23, Kasturba Gandhi Marg, New Delhi-110001
 Tel: 011-46451100, 23315941, Email: tss@shrirampistons.com, Website: www.shrirampistons.com