



PISTONS PINS RINGS
ENGINE VALVES







SHRIRAM PISTONS & RINGS

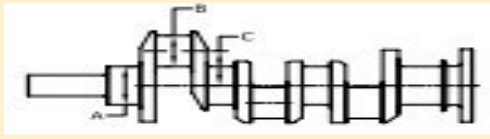

AUTO COMPONENTS
& ASSEMBLIES

CAR & SCV RANGE- CRANKSHAFT

Model	No. of Cyl.	Units					Material	SPR Part No.
			A	B	C			
HYUNDAI SANTRO		4	INCHES MM	1.969 50.00	1.772 45.00	1.575 40.00	CK45	CS-1973
HYUNDAI ACCENT		4	INCHES MM	1.967 49.95	1.772 45.00	1.831 46.50	CK45	CS-1969
MARUTI 800cc		3	INCHES MM	1.969 50.00	1.496 38.00	1.417 36.00	CK45	CS-1987

A- MAIN JOURNAL BEARING DIAMETER

B- CRANK PIN JOURNAL DIAMETER

C- THROW (2 THROW=STROKE LENGTH)



PISTONS PINS RINGS
ENGINE VALVES





SHRIRAM PISTONS & RINGS



AUTO COMPONENTS
& ASSEMBLIES

CAR & SCV RANGE- CRANKSHAFT

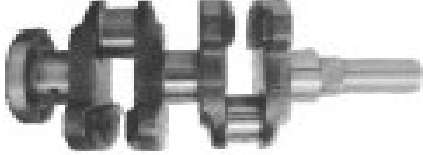
MARUTI GYPSY		4	INCHES MM	1.969 50.00	1.496 38.00	1.417 36.00	S.G IRON	CS-2086
TATA INDICA (DIESEL)		4	INCHES MM	1.969 50.00	1.772 45.00	1.575 40.00	CK45	CS-1971
TATA ACE (DIESEL)		2	INCHES MM	1.967 49.97	1.770 44.97	1.575 40.00	CK45	CS-1983

A- MAIN JOURNAL BEARING DIAMETER

B- CRANK PIN JOURNAL DIAMETER

C- THROW (2 THROW=STROKE LENGTH)