



SHRIRAM PISTONS & RINGS LTD.

MD: TS: 24/OCT'24

INTRODUCTION CIRCULAR – TVS APACHE RTR 160 2V BS VI - PISTON ASSEMBLY

USHA is pleased to launch 'TVS APACHE RTR 160 2V BS VI' piston assembly in its aftermarket bi-wheeler product range.



This piston assembly has following special features: -

PISTON:-

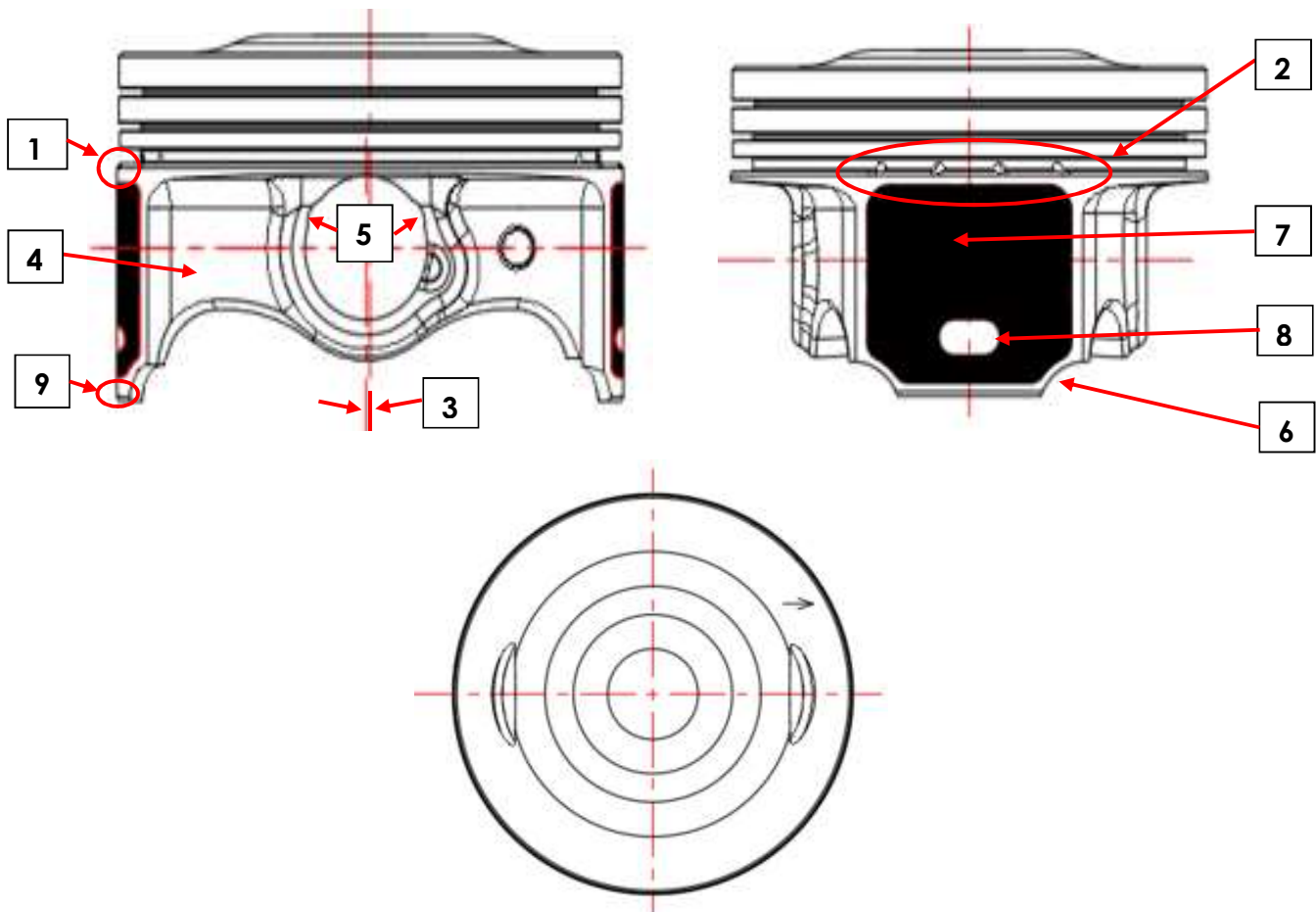



Unique features of USHA 'TVS APACHE RTR 160 2V BS VI' piston are as follows: -

SL. NO.	SPECIAL FEATURE	BENEFITS TO CUSTOMER
1)	CHAMFER AT BOTTOM OF OIL RING GROOVE: An all-round chamfer is provided just below the oil ring groove area.	<ul style="list-style-type: none"> Provides all time lubrication to piston skirt No piston seizure in extreme limits of normal working conditions
2)	HOLES IN OIL RING GROOVE AREA: 04 nos. of holes are provided in the oil ring groove on either side of piston skirt, half in groove & half in skirt.	<ul style="list-style-type: none"> Faster drainage of excess oil Reduces oil consumption
3)	PISTON - PIN BORE OFFSET: Piston is provided with piston pin bore offset to avoid piston slap. Piston pin bore offset means that the centre line of piston is slightly offset from the centre line of pin bore. Due to this offset, piston tilts at TDC & BDC smoothly & prevents slapping with cylinder surface.	<ul style="list-style-type: none"> Reduced engine noise
4)	AS CAST RELIEF IN PIN BORE AREA: As cast relief in pin bore area helps in faster drainage of oil towards sump & also avoids chances of seizure on minor axis.	<ul style="list-style-type: none"> Low oil consumption Longer life
5)	PIN BORE BROACHING: Double broach is done on either side, at the upper portion of the pin bore.	<ul style="list-style-type: none"> Relieves stress in pin bore Improves pin bore lubrication
6)	'Nano-friKS COATING' ON PISTON SKIRT:	<ul style="list-style-type: none"> Helps in initial lubrication & seizure free operation Better wear resistance Reduces engine noise
7)	MEASURING POINTS ON PISTON SKIRT:	<ul style="list-style-type: none"> Provided for easy diameter verification
8)	SLIPPER DESIGN: Slipper design helps in reducing piston weight.	<ul style="list-style-type: none"> Improves fuel efficiency Low noise during engine working
9)	SCRAPPING CHAMFER: A smooth chamfer is provided at the bottom end of the piston skirt.	<ul style="list-style-type: none"> Helps in regulating oil supply, reduces skirt wear & hence longer life

TECHNICAL DATA – 'TVS APACHE RTR 160 2V BS VI' PISTON	
USHA Code → NCS86	
Nominal Bore Diameter	62.00
Piston Diameter	61.982
Recommended Piston-Liner Clearance	0.018
Compression Height	22.10
Total Height	38.10
Gudgeon Pin Length X OD	39.80 X 15.0
All dimensions in 'mm'	

PISTON RINGS:-

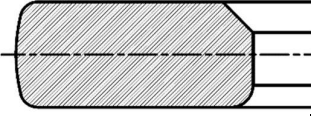
USHA 'TVS APACHE RTR 160 2V BS VI' piston is supplied with a unique '3S VENT' ring set for low oil & fuel consumption. The technical details of '3S VENT' ring set are as under:

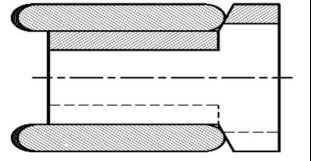
TECHNICAL DATA – 'TVS APACHE RTR 160 2V BS VI' – '3S VENT' RINGS						
Ring	Ring Configuration	Axial Thickness (mm)	Closed Gap		Surface Treatment	Cross Section
			(mm)	(Thou)		
Top	Steel Inside Bevel (HPIBGN)	0.80	0.20-0.35	08-14	Gas Nitriding	
Second	Steel Taper (HPCRT)	0.80	0.25-0.40	10-16	Chrome Plating/ Parkerising	
Oil	RIKVENT	1.50	0.20-0.70 (Rails)	08-28	Chrome Plated Rails/ Parkerising	

Above features make USHA 'TVS APACHE RTR 160 2V BS VI' piston assembly unique, produced to give better performance & longer life.



Technical Product News is an exclusive update of product & information from
Shriram Pistons & Rings Ltd., 3rd Floor, Himalaya House, 23, Kasturba Gandhi Marg, New Delhi-110001
Tel: 011-46451100, 23315941, Email: tss@shrirampistons.com, Website: www.shrirampistons.com