



MD: TS: 37/MAR'26

INTRODUCTION CIRCULAR- LEYLAND HINO H6 4V BS6 IP DVM – PAS & RS

USHA is pleased to launch 'LEYLAND HINO H6 4V BS6 IP DVM' piston assembly & ring set in its aftermarket HCV product range.



This piston set has following special features: -

PISTON:-

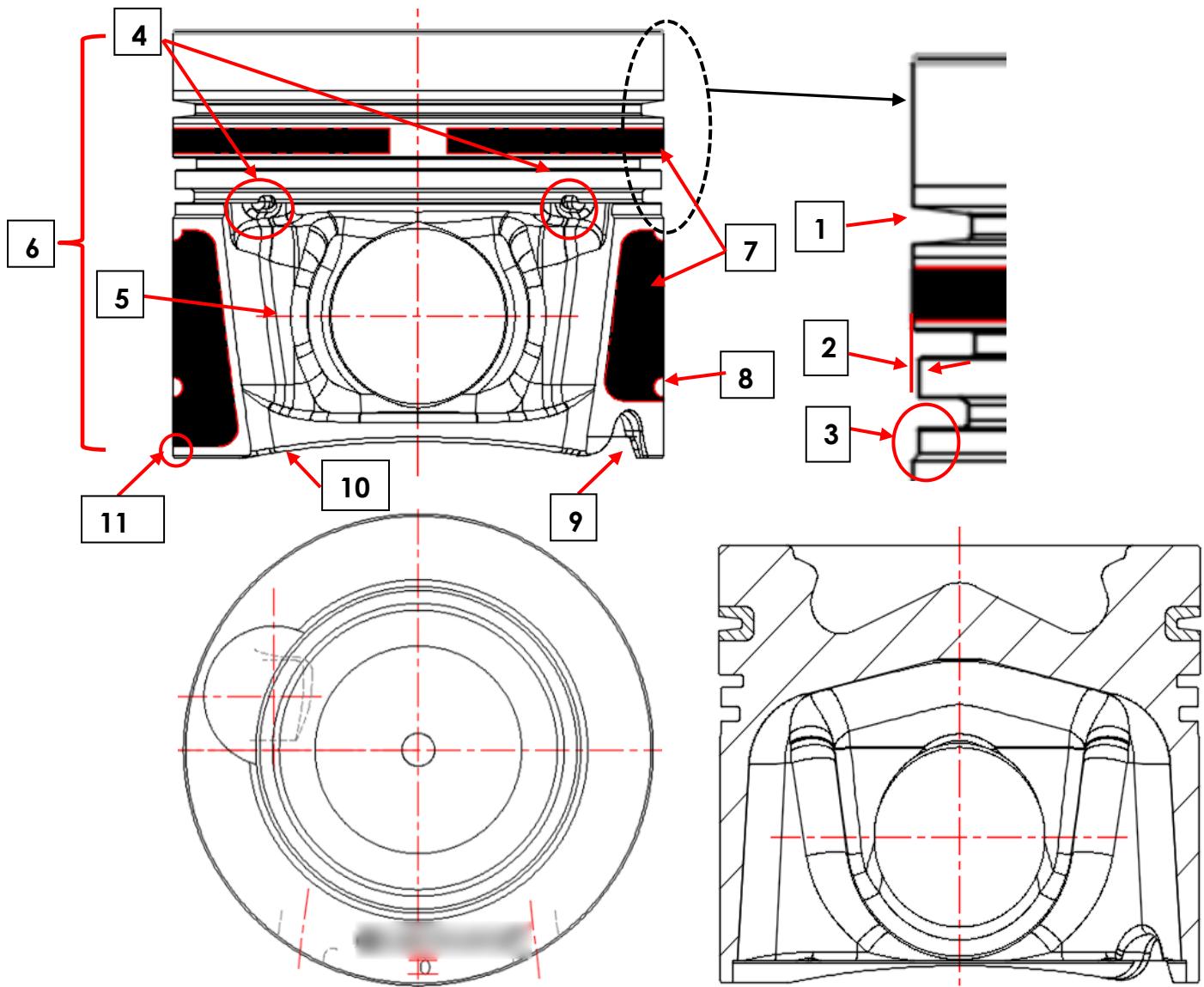

Unique features of USHA '**LEYLAND HINO H6 4V BS6**' piston are as follows:

SL. NO.	SPECIAL FEATURE	BENEFITS TO CUSTOMER
1)	<p>HIGH NICKEL WEAR RESISTANT RING CARRIER (RCP): Top groove of this piston is made of high nickel wear resistant ring carrier insert which is manufactured using latest centrifugal casting technology.</p> <p>KEYSTONE RING GROOVE GEOMETRY: Helps in squeezing out excess oil from the groove preventing carbon deposition & sludge formation.</p>	<ul style="list-style-type: none"> • Longer life of piston due to negligible wear of top groove
2)	<p>CUT BACK IN 2ND RING LAND: This piston has a cut back in second ring land for better seating, stability & functioning of intermediate ring.</p>	<ul style="list-style-type: none"> • Helps in controlling blow-by & reducing oil consumption
3)	<p>'J' CUT: Piston has been provided with a unique 'J' cut below the oil ring groove area.</p>	<ul style="list-style-type: none"> • Provides all time lubrication to piston skirt • No piston seizure in extreme limits of normal working conditions
4)	<p>QUICK OIL RETURN SLOTS (QORS): Two nos. of Quick Oil Return Slots (QORS) are provided on either side of piston above the pin bore, half in groove & half in window.</p>	<ul style="list-style-type: none"> • Faster drainage of excess oil, hence low oil consumption
5)	<p>AS CAST HYDRODYNAMIC WINDOW: 'As Cast' hydrodynamic window not only provides more space for oil drainage, but also provides more bearing area to piston skirt which helps in guiding ring's movement.</p>	<ul style="list-style-type: none"> • Reduces chances of seizure at minor axis, hence longer piston life
6)	<p>PISTON SURFACE COMPLETELY BONDERISED:</p>	<ul style="list-style-type: none"> • Bonderising helps in preventing oxidation of piston • Also provides porous surface for oil retention, thereby reducing wear
7)	<p>'D-10 COATING' ON PISTON SKIRT & 1ST RING LAND:</p>	<ul style="list-style-type: none"> • Helps in initial lubrication & seizure free operation • Better wear resistance • Reduces engine noise
8)	<p>MEASURING POINTS ON PISTON SKIRT:</p>	<ul style="list-style-type: none"> • Provided for easy diameter verification
9)	<p>SLOT FOR PISTON COOLING NOZZLE (PCN) JET: Provides room for oil cooling jet.</p>	<ul style="list-style-type: none"> • Helps in directing oil flow underneath piston combustion cavity results in faster dissipation of heat

10)	SLIPPER DESIGN: Slipper design helps in reducing piston weight.	<ul style="list-style-type: none"> Improves fuel efficiency Low noise during engine working
11)	SCRAPING CHAMFER: A smooth chamfer is provided at the bottom end of the piston skirt.	<ul style="list-style-type: none"> Helps in regulating oil supply, reduces skirt wear & hence longer life

TECHNICAL DATA- LEYLAND HINO H6 4V BS6 PISTON (Ø 104.00 mm)	
USHA CODE → H35	
Nominal Bore Diameter	104.00
Piston Diameter	103.92
Recommended Piston-Liner Clearance	0.08
Compression Height	60.15
Total Height	90.15
Gudgeon Pin Length X OD	85.00 X 37.00
All dimensions in 'mm'	

PISTON RINGS:-



This ring set has following special features:

ITEM	CONFIGURATION	FEATURES	BENEFITS TO CUSTOMER
Top Ring	Keystone Steel Inside Bevelled Ion Plated {HPKIP}	Steel Material	Top ring is made up of steel alloy which possesses good elasticity, excellent resistance to twisting, breakage & wear, hence longer life.
		Keystone Geometry	Special keystone geometry keeps squeezing out excess oil from the groove, thereby minimizing chances of carbon deposition, sludge formation & preventing ring sticking inside the groove.

		Ion Plating	Ion plating is a Japanese technology based on PVD (Physical Vapour Deposition) through which chrome and nitrogen ions get deposited on ring outer surface. This improves wear & scuff resistance, hence extended life.
		Parkerising	Side faces are parkerised to provide porous surface for oil retention resulting in better lubrication, hence lesser wear.
2 nd Ring	Reverse Torsion {RT}	Taper face	Ring has a Taper on OD to provide line contact with liner resulting in higher wall pressure, hence better sealing.
		Inside bevel on lower face	Ring has a bevel cut on lower inside face due to which ring twists in anti-clockwise direction during suction stroke which locks the groove to avoid blow-by & upward movement of oil.
		Parkerising	Ring is fully parkerised to provide porous surface for oil retention resulting in better lubrication & lesser wear.
Oil Ring	Diesel Vent 'M' shape (DVM)	Steel Material	Ring is made up of steel for longer life.
		Gas Nitriding (GN)	The ring is gas nitrided to provide wear resistance to all surfaces, hence longer life.
		Highly Conformable	DVM ring has built-in tension and spring beneath makes it highly conformable to the bore wear for better oil scraping.
		Sharp Scraping Ring Lands	The sharp ring lands with high wall pressure ensures better scraping of oil resulting in lower oil consumption.
		Multiple Oil Drainage Slots	Ensure faster drainage of oil.
		Excellent Flatness	Side faces of DVM oil ring remain flat and do not swell as in case of ordinary oil ring, for a free movement in groove.
		Light in Weight	Ring is lighter in weight than ordinary oil ring which reduces fluttering of ring in groove thereby avoids pumping up of oil, hence low oil consumption.

Technical data of 'LEYLAND HINO H6 4V BS6 IP DVM' ring set is as under:

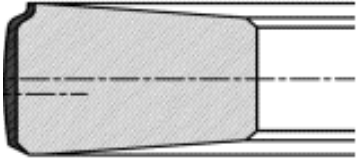
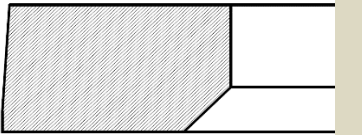
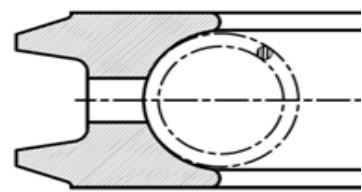
TECHNICAL DATA- LEYLAND HINO H6 4V BS6 'IP DVM' RING SET (ø 104.00 mm)						
						USHA CODE→ H35
Ring	Ring Config.	Axial Thickness (mm)	Closed Gap		Surface Treatment	Cross Section
			(mm)	(Thou)		
Top	HPKIP	3.00	0.25-0.35	10-14	Ion Plated/ Parkerising	
2 nd	RT	2.50	0.60-0.75	24-30	Parkerising	
Oil	DVM	3.00	0.25-0.45	10-18	Gas Nitriding	

P.S: HINO H6 4V BS6 'IP DVM' ring set's **axial thickness** is same as that of HINO H6 2VP BS6/ BS3B (H17) ring set, but due to the difference in radial thickness of TOP-1 ring, ring sets are **not interchangeable**.

Above features make USHA LEYLAND HINO H6 4V BS6 IP DVM piston assembly unique, produced to give better performance & longer life.



Technical Product News is an exclusive update of product & information from Shriram Pistons & Rings Ltd., 3rd Floor, Himalaya House, 23, Kasturba Gandhi Marg, New Delhi-110001
Tel: 011-46451100, 23315941, Email: tss@shrirampistons.com, Website: www.shrirampistons.com