



USHA is pleased to launch '**MARUTI JIMNY 1.5L BS6 PETROL**' piston set in its Car/ PV product range.



This piston set has following special features:

**PISTON:**

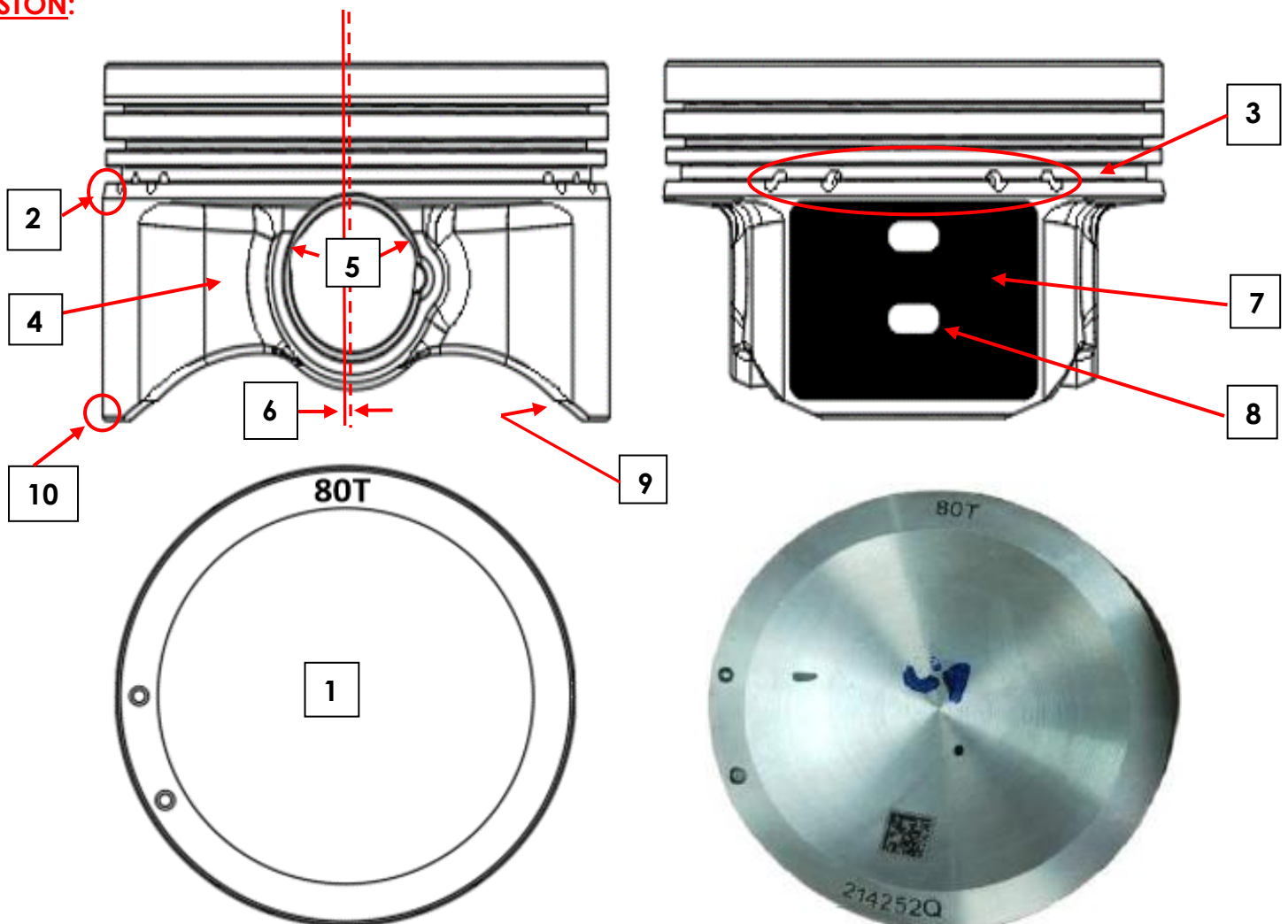

Unique features of this piston are as follows: -

SL. NO.	SPECIAL FEATURE	BENEFITS TO CUSTOMER
1)	<b>SHALLOW CAVITY:</b> This piston crown is provided with a shallow cavity for an effective combustion.	<ul style="list-style-type: none"> <li>• Lower emissions</li> <li>• Better fuel efficiency</li> </ul>
2)	<b>CHAMFER AT BOTTOM OF OIL RING GROOVE:</b> This piston has an all-round chamfer just below the oil ring groove area.	<ul style="list-style-type: none"> <li>• Provides all time lubrication to piston skirt</li> <li>• No piston seizure in extreme limits of normal working conditions</li> </ul>
3)	<b>HOLES IN OIL RING GROOVE AREA:</b> 04 nos. of holes are provided on either side of piston, half in groove & half in window.	<ul style="list-style-type: none"> <li>• Faster drainage of excess oil</li> <li>• Reduces oil consumption</li> </ul>
4)	<b>AS CAST RELIEF IN PIN BORE AREA:</b> This piston is provided with as cast relief in pin bore area which not only helps in faster drainage of oil towards sump but also in avoiding chances of seizure on minor axis.	<ul style="list-style-type: none"> <li>• Low oil consumption</li> <li>• Longer life</li> </ul>
5)	<b>PIN BORE BROACHING:</b> Double broach is done on either side, at the upper portion of the pin bore.	<ul style="list-style-type: none"> <li>• Relieves stress in pin bore</li> <li>• Improves pin bore lubrication</li> </ul>
6)	<b>PISTON - PIN BORE OFFSET:</b> Piston is provided with a piston pin bore offset to avoid piston slap. Piston pin bore offset means that the centre line of piston is slightly offset from the centre line of pin bore. Due to this offset, piston tilts at TDC & BDC smoothly, that prevents slapping with liner.	<ul style="list-style-type: none"> <li>• Reduced engine noise</li> </ul>
7)	<b>'Nano-friKS COATING' ON PISTON SKIRT:</b>	<ul style="list-style-type: none"> <li>• Helps in initial lubrication &amp; seizure free operation</li> <li>• Better wear resistance</li> <li>• Reduces engine noise</li> </ul>
8)	<b>MEASURING POINTS ON PISTON SKIRT:</b>	<ul style="list-style-type: none"> <li>• Provided for easy diameter verification</li> </ul>
9)	<b>SLIPPER DESIGN:</b> Slipper design helps in reducing piston weight.	<ul style="list-style-type: none"> <li>• Improves fuel efficiency</li> <li>• Low noise during engine working</li> </ul>
10)	<b>SCRAPING CHAMFER:</b> A smooth chamfer is provided at the bottom end of the piston skirt.	<ul style="list-style-type: none"> <li>• Helps in regulating oil supply, reduces skirt wear &amp; hence longer life</li> </ul>

**TECHNICAL DATA – ‘MARUTI JIMNY 1.5L BS6 PETROL’ PISTON****USHA CODE → C71**

Nominal Bore Diameter	74.00
Piston Diameter	73.984
Recommended Piston-Liner Clearance	0.016
Compression Height	26.00
Total Height	43.25
Piston Pin length X diameter	47.00 X 18.00
All dimensions are in ‘mm’	

A mark **‘80T’** is punched on crown of this piston for identification of this model.

Above features make USHA **‘MARUTI JIMNY 1.5L BS6 PETROL’** piston set unique, produced to give better performance & longer life, when fitted with **‘MARUTI ERTIGA/ BREZZA/ CIAZ 1.5L (P) 2018 ONWARDS-HPVENT’** ring set (USHA Code→ **C31**), which is already in supply.



Technical Product News is an exclusive update of product & information from  
Shriram Pistons & Rings Ltd., 3rd Floor, Himalaya House, 23, Kasturba Gandhi Marg, New Delhi-110001  
Tel: 011-46451100, 23315941, Email: [tss@shrirampistons.com](mailto:tss@shrirampistons.com), Website: [www.shrirampistons.com](http://www.shrirampistons.com)