



USHA is pleased to launch '**GENSET 200**' piston assembly in its aftermarket Industrial/ Off-road application product range.



This piston assembly has following special features: -

PISTON:-

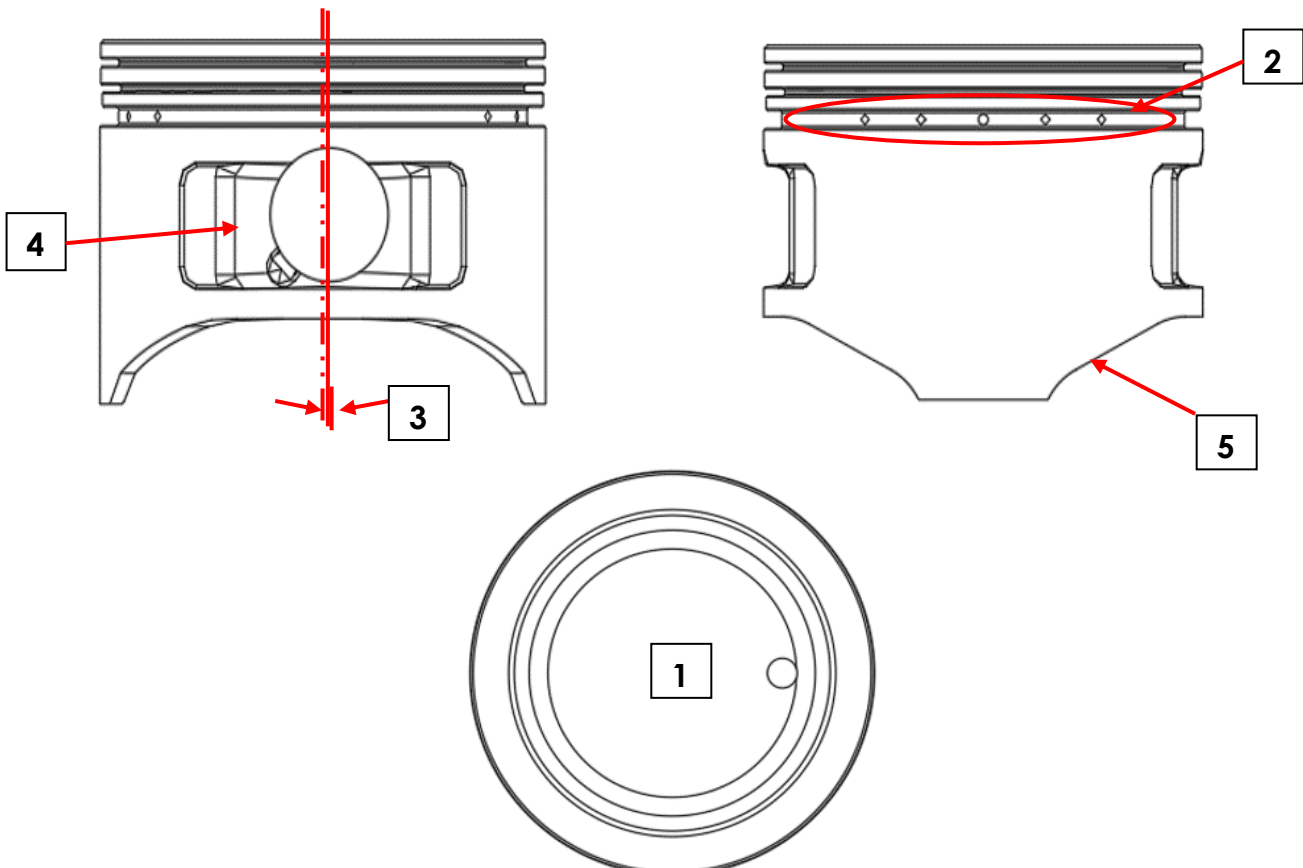



Unique features of USHA '**GENSET 200**' piston are as follows: -

SL. NO.	SPECIAL FEATURE	BENEFITS TO CUSTOMER
1)	AS CAST CROWN: This piston has an as cast crown for better grain structure which improves piston strength & heat resistance etc.	<ul style="list-style-type: none"> Improves piston life
2)	HOLES IN OIL RING GROOVE AREA: 06 nos. of holes are provided in the oil ring groove on either side of piston skirt.	<ul style="list-style-type: none"> Faster drainage of excess oil Reduces oil consumption
3)	PISTON - PIN BORE OFFSET: Piston is provided with piston pin bore offset to avoid piston slap. Piston pin bore offset means that the centre line of piston is slightly offset from the centre line of pin bore. Due to this offset, piston tilts at TDC & BDC smoothly & prevents slapping with cylinder surface.	<ul style="list-style-type: none"> Reduced engine noise
4)	AS CAST RELIEF IN PIN BORE AREA: As cast relief in pin bore area helps in faster drainage of oil towards sump & also avoids chances of seizure on minor axis.	<ul style="list-style-type: none"> Low oil consumption Longer life
5)	SLIPPER DESIGN: Slipper design helps in reducing piston weight.	<ul style="list-style-type: none"> Improves fuel efficiency Low noise during engine working

TECHNICAL DATA – ' GENSET 200 ' PISTON	
USHA Code → 106	
Nominal Bore Diameter	68.00
Piston Diameter	67.975
Recommended Piston-Liner Clearance	0.025
Compression Height	23.50
Total Height	49.00
Gudgeon Pin Length X OD	53.40 X 18.00
All dimensions in 'mm'	

PISTON RINGS:-

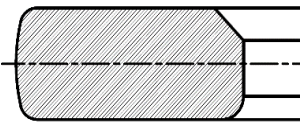
USHA 'GENSET 200' piston is supplied with a unique '3S VENT' ring set for low oil & fuel consumption. The technical details of ring set are as under:

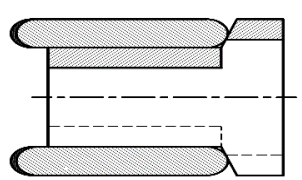
TECHNICAL DATA – 'GENSET 200 – '3S VENT' RINGS						
Ring	Ring Configuration	Axial Thickness (mm)	Closed Gap		Surface Treatment	Cross Section
			(mm)	(Thou)		
Top	Steel Inside Bevel (HPIBGN)	1.00	0.20-0.35	08-14	Gas Nitriding	
Second	Steel Taper (HPT)	1.00	0.35-0.50	14-20	Parkerising	
Oil	RIKVENT	2.50	0.20-0.70 (Rails)	08-28	Chrome Plated Rails/ Parkerising	

Above features make USHA 'GENSET 200' piston assembly unique, produced to give better performance & longer life.



Technical Product News is an exclusive update of product & information from Shriram Pistons & Rings Ltd., 3rd Floor, Himalaya House, 23, Kasturba Gandhi Marg, New Delhi-110001
 Tel: 011-46451100, 23315941, Email: tss@shrirampistons.com, Website: www.shrirampistons.com